

SmartPro™ Monitoring Systems

Minimize Operational Risk

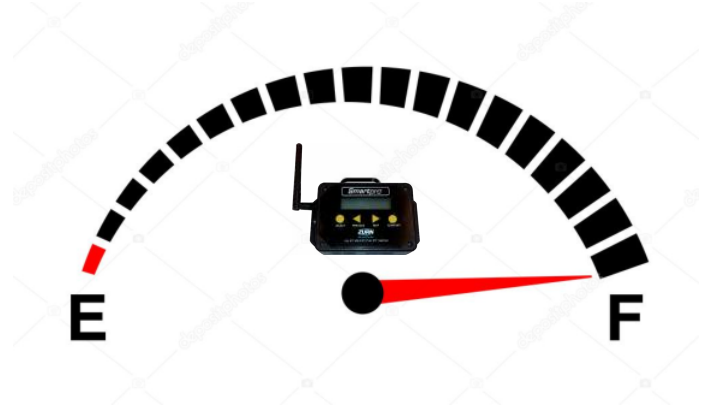

To compliment Zurn Green Turtle's strong product offerings, innovative instrumentation and automation accessories were created in an effort to minimize operational risk and ensure compliance. The result is SmartPro™, a complete line of monitoring systems – now available in wireless radio, cell network or gateway cloud connectivity.

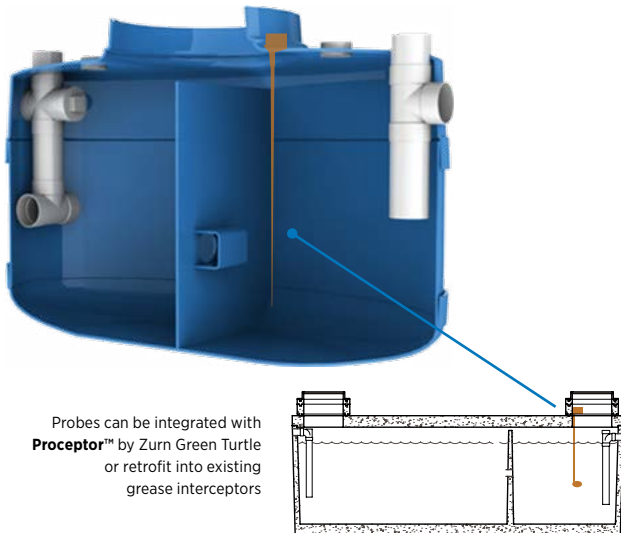

Probes can be integrated with **Proceptor™** by Zurn Green Turtle or retrofit into existing grease interceptors

Wireless Technology

- Effortless liquid level management
- Monitor grease and oil level, sludge level, and even temperature with the push of a button, or view remotely.
- Eliminate the back-breaking task of lifting cast iron covers to see inside the tank
- Alarm signals when it is time to pump or when liquid level is too high
- Retrofit most interceptor systems and partner with pumpers to reduce pumping costs
- Total peace-of-mind regulatory compliance

Stay on Top of Costs

Why waste money paying to pump a tank that is not yet at capacity? SmartPro™ lets you know exactly how much grease, oil and sediment you have in your interceptor. It will even allow you to verify level back-ups and good pump-outs.

Stay In Compliance

While you may find it difficult to estimate the levels in your tank, the enforcement officer will not. Avoid fines by knowing how much grease you really have.

SmartPro™



Wireless RF
Grease, Oil, Sediment Monitor

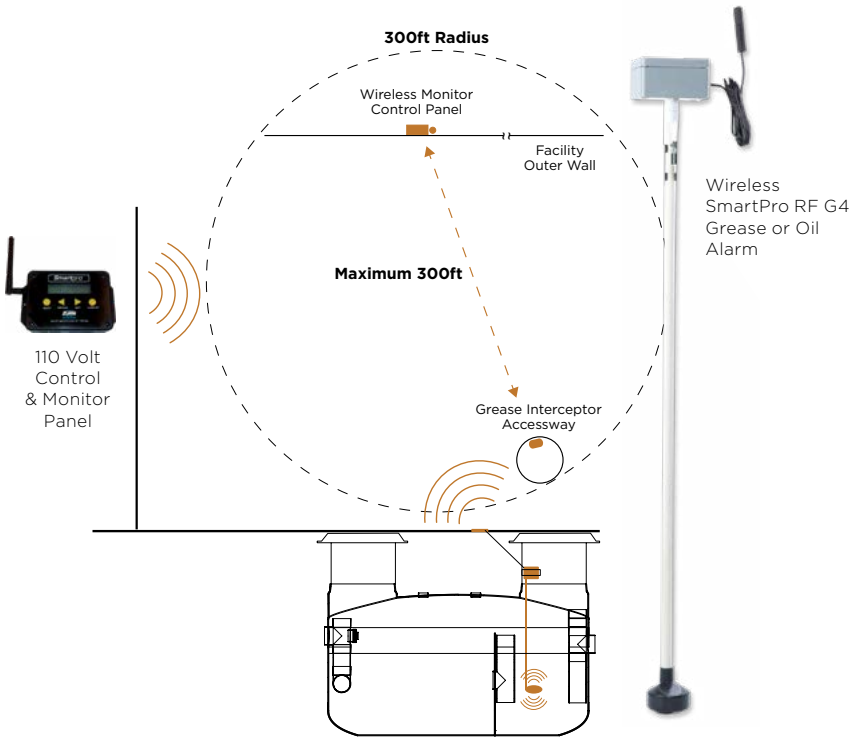

SmartPro RF G4 shown installed in outlet side of dual manway Proceptor

NEW Additions

NEW Wireless
SmartPro G3 Cellular
Grease or Oil Alarm

NEW Wireless
SmartPro G5 Grease or
Oil Alarm with Gateway

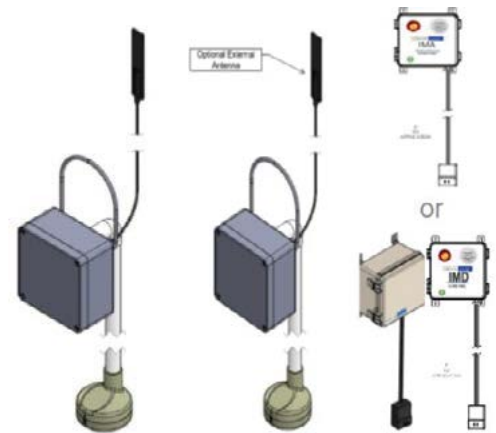

Wired
Grease, Oil Monitor

Wired Grease and Oil Monitor and Alarm

A visual and audible alarm alerts the operator when the oil or grease collection system's liquid level interface has reached a pre-set capacity level and the system needs to be pumped out.

Wired Liquid Level Monitor and Alarm

A visual and audible alarm alerts the operator that the fluid has reached a predetermined level and the system needs to be pumped out or maintained.

Interstitial Monitoring for Double-Walled Tanks

A visual and audible alarm alerts the operator that liquid has been detected between the two walls of a double wall tank so that corrective measures can be taken. Wired plug-in system.



ZURN INDUSTRIES, LLC 511 West Freshwater Way, Milwaukee, WI 53204, 855.663.9876

In Canada: ZURN INDUSTRIES LIMITED 7900 Goreway Drive, Unit 10, Brampton, Ontario L6T 5W6, 877.892.5216

Form No. 700-020, 6/21



US 1.855.ONE.ZURN CANADA 1.877.892.5216 ZURN.COM